

A DWR
TWIN
CYLINDER
SERIES

SAFETY
ENDURANCE

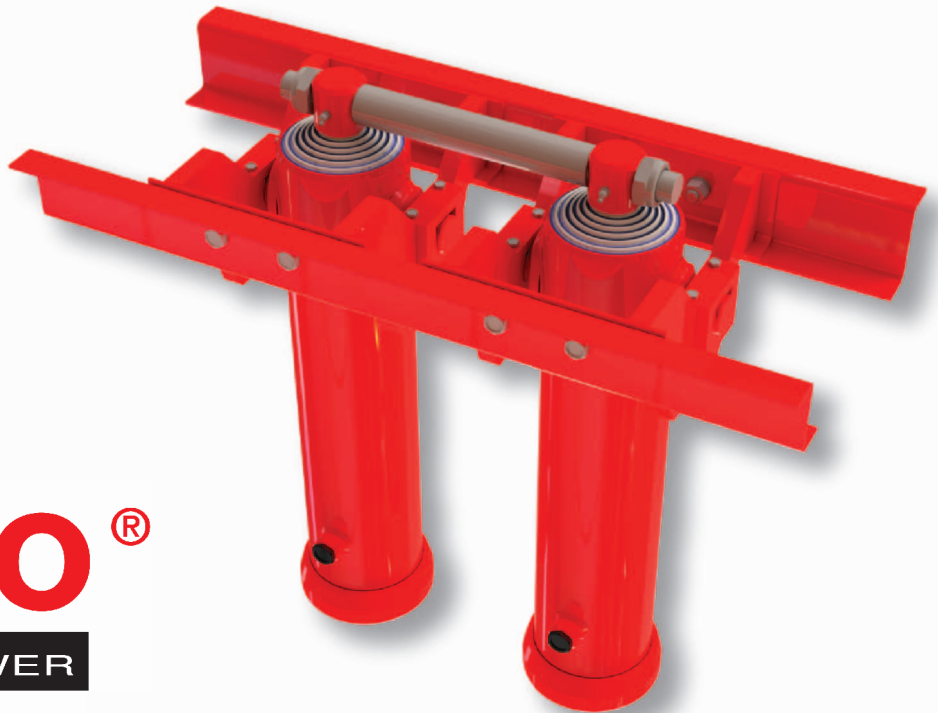

Binotto®

THE TIPPING POWER

HIGH PRESSURE
HARD CHROMED



APPLICATIONS

DESCRIPTION	STAGES [n]	STROKE [mm]	INITIAL STAGE ϕ [mm]	D [mm]	H [mm]	I [mm]	W.P. [bar]
A DWR 4-1220-130	4	1220	108	150	472	32	250
A DWR 4-1600-130	4	1600	108	150	572	32	250
A DWR 4-1780-130	4	1780	108	150	622	32	250
A DWR 4-1940-130	4	1940	108	150	672	32	250
A DWR 5-2825-149	5	2825	126	155	817	32	250
A DWR 5-3125-149	5	3125	126	155	867	32	250
A DWR 6-3870-149	6	3870	126	170	933	32	250
A DWR 6-4350-149	6	4350	126	240	1033	32	250
A DWR 5-2825-168	5	2825	145	155	818	32	250
A DWR 5-3225-168	5	3225	145	155	868	32	250
A DWR 6-3630-168	6	3630	145	155	872	32	250
A DWR 6-3870-168	6	3870	145	155	922	32	250
A DWR 6-4350-168	6	4350	145	155	1022	32	250
A DWR 7-4355-168	7	4355	145	175	888	32	250
A DWR 7-4515-168	7	4515	145	175	938	32	250
A DWR 6-3870-188	6	3870	165	205	918	32	250
A DWR 7-4515-213	7	4515	187	205	926	32	250

MODEL SELECTION

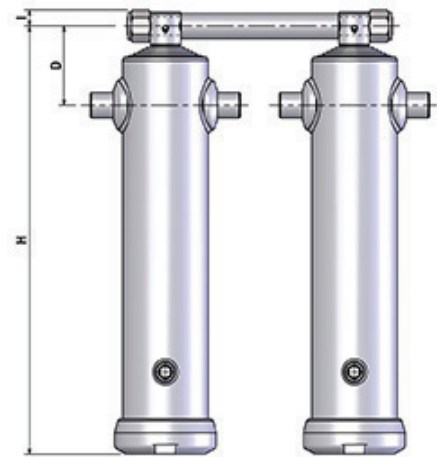

ACCESSORIES

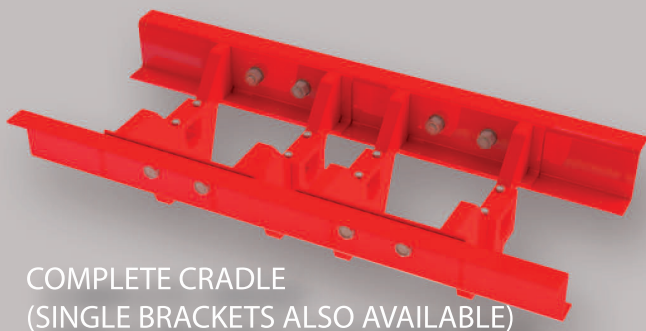

OTHER PRODUCT SERIES

